

Deutsches Institut für Bautechnik

Anstalt des öffentlichen Rechts

Kolonnenstr. 30 L
10829 Berlin
Germany

Tel.: +49(0)30 787 30 0
Fax: +49(0)30 787 30 320
E-mail: dibt@dibt.de
Internet: www.dibt.de

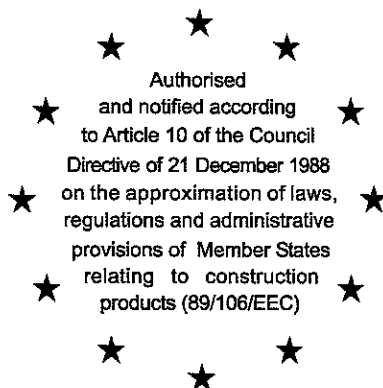

DIBt

Mitglied der EOTA
Member of EOTA

European Technical Approval ETA-08/0040

English translation prepared by DIBt - Original version in German language

Handelsbezeichnung
Trade name

Setzbolzen: HSBR 14 und HSBR 14 Tube
Setzgeräte: P230, P230L und P525L

Powder actuated fasteners: HSBR 14 and HSBR 14 Tube

Fastening tools: P230, P230L and P525L

Zulassungsinhaber
Holder of approval

SPIT
Route de Lyon
26501 Bourg-lès-Valence cedex
FRANKREICH

Zulassungsgegenstand
und Verwendungszweck

SPIT Setzbolzen HSBR 14 und HSBR 14 Tube in Kombination mit den SPIT Setzgeräten P230, P230L und P525L für die Befestigung von Stahlblech an Stahlunterkonstruktionen.

*Generic type and use
of construction product*

SPIT powder actuated fasteners HSBR 14 and HSBR 14 Tube in combination with SPIT fastening tools P230, P230L and P525L for fastening of steel sheeting to steel members.

Geltungsdauer: vom
Validity: from

6 March 2008

bis
to

6 March 2013

Herstellwerk
Manufacturing plant

SPIT
- ZI de Marcerolles -
Rue A. Nobel
26500 BOURG-LÉS VALENCE
FRANKREICH

Diese Zulassung umfasst
This Approval contains

10 Seiten einschließlich 3 Anhänge
10 pages including 3 annexes



Europäische Organisation für Technische Zulassungen
European Organisation for Technical Approvals

I LEGAL BASES AND GENERAL CONDITIONS

- 1 This European technical approval is issued by Deutsches Institut für Bautechnik in accordance with:
 - Council Directive 89/106/EEC of 21 December 1988 on the approximation of laws, regulations and administrative provisions of Member States relating to construction products¹, modified by Council Directive 93/68/EEC² and Regulation (EC) N° 1882/2003 of the European Parliament and of the Council³;
 - Gesetz über das In-Verkehr-Bringen von und den freien Warenverkehr mit Bauprodukten zur Umsetzung der Richtlinie 89/106/EWG des Rates vom 21. Dezember 1988 zur Angleichung der Rechts- und Verwaltungsvorschriften der Mitgliedstaaten über Bauprodukte und anderer Rechtsakte der Europäischen Gemeinschaften (Bauproduktengesetz - BauPG) vom 28. April 1998⁴, zuletzt geändert durch Gesetz vom 06.01.2004⁵;
 - Common Procedural Rules for Requesting, Preparing and the Granting of European technical approvals set out in the Annex to Commission Decision 94/23/EC⁶.
- 2 Deutsches Institut für Bautechnik is authorized to check whether the provisions of this European technical approval are met. Checking may take place in the manufacturing plant. Nevertheless, the responsibility for the conformity of the products to the European technical approval and for their fitness for the intended use remains with the holder of the European technical approval.
- 3 This European technical approval is not to be transferred to manufacturers or agents of manufacturers other than those indicated on page 1, or manufacturing plants other than those indicated on page 1 of this European technical approval.
- 4 This European technical approval may be withdrawn by Deutsches Institut für Bautechnik, in particular pursuant to information by the Commission according to Article 5(1) of Council Directive 89/106/EEC.
- 5 Reproduction of this European technical approval including transmission by electronic means shall be in full. However, partial reproduction can be made with the written consent of Deutsches Institut für Bautechnik. In this case partial reproduction has to be designated as such. Texts and drawings of advertising brochures shall not contradict or misuse the European technical approval.
- 6 The European technical approval is issued by the approval body in its official language. This version corresponds fully to the version circulated within EOTA. Translations into other languages have to be designated as such.

1 Official Journal of the European Communities L 40, 11.02.1989, p. 12

2 Official Journal of the European Communities L 220, 30.08.1993, p. 1

3 Official Journal of the European Union L 284, 31.10.2003, p. 25

4 Bundesgesetzblatt I, p. 812

5 Bundesgesetzblatt I, p.2, 15

6 Official Journal of the European Communities L 17, 20.01.1994, p. 34

II SPECIFIC CONDITIONS OF THE EUROPEAN TECHNICAL APPROVAL

1 Definition of the product and intended use

1.1 Definition of the construction product

The products are mechanical fasteners (powder actuated fasteners / cartridge fired pins)⁷ made of steel. The fasteners comprise a pin (nominal diameter: 4.5 mm) which is assembled with one washer. The washer in connection with the same diameter pin-head serves to guide the fasteners while they are being driven into the base material. The washer also serves to improve the bearing area. Special fastening tools are used in order to install the fasteners. The driving force of the fastening tools is provided by the power load of the used cartridge (several cartridge strengths available). The application limit depends on the strength and thickness of the base material.

The dimensions and materials of the fastener are given in Annex 1. The difference of the fastening tools is the kind of feeding: single fasteners or collated in tube magazines. Table 1 provides an overview of the 3 powder actuated fastening systems approved.

Table 1 Overview of the fastening systems

Fastening Tool	Fastener	Features
P230	HSBR-14	The P230 is used to drive single fasteners.
P230L	HSBR-14 Tube	The P230L is a standup tool which is based on the P230. The fasteners are collated in tube magazines.
P525L	HSBR-14 Tube	The P525L is a standup tool which is based on the P230. The fasteners are collated in tube magazines.

Fasteners, fastening tools and cartridges are shown in Annex 1.

The fastener and the corresponding connections are subject to tension and/or shear forces (see Annex 2).

1.2 Intended use

The fasteners are intended to be used for fastening of steel sheeting with steel grades $\geq S280$ and a thickness $t_1 = 0.63 \text{ mm} - 3.0 \text{ mm}$ (max. 5 mm for 2 - 4 layers) to steel members with steel grades $\geq S235$ and a thickness $t_{fl} \geq 6 \text{ mm}$, provided the relevant application limits are taken into account. The sheeting can either be used as cladding or as load bearing wall and roof element.

The fastener can also be used for the fastening of other thin gauge steel members.

The intended use only comprises fasteners and connections which are not directly exposed to external weather conditions or moist atmospheres.

The provisions made in this European technical approval are based on an assumed working life of the powder actuated fasteners of 25 years. The indications given on the working life cannot be interpreted as a guarantee given by the producer, but are to be regarded only as a means for choosing the right products in relation to the expected economically reasonable working life of the work.

⁷ Both terms (powder actuated fastener and cartridge fired pin) are commonly used.

2 Characteristics of product and methods of verification

2.1 Characteristics of product

The fasteners shall correspond to the drawing given in Annex 1.

The characteristic material values, dimensions and tolerances of the fasteners neither indicated in this section nor in Annex 1 shall correspond to the respective values laid down in the technical documentation⁸ to this European Technical Approval.

The characteristic and design values of the shear and tension resistance of the connections made with the fastener as well as the application limits are given in Annex 3.

The fasteners are considered to satisfy the requirements of performance class A1 of the characteristic reaction to fire.

2.2 Methods of verification

The assessment of the fitness of the fasteners for the intended use (see Annex 1) in relation to the requirements for mechanical resistance and stability, safety in case of fire and safety in use in the sense of the Essential Requirements No. 1, No. 2 and No. 4 has been made in accordance with the "Common Understanding of Assessment Procedure (CUAP) for Cartridge Fired Pin" (Final version, February 2004; ETA request No 06.02/05).

Concerning Essential Requirement No. 2 (Safety in case of fire) the following applies:

The assessment of the resistance to fire performance is only relevant to the assembled system (fasteners, sheeting, substructure) which is not part of the ETA.

The fasteners are considered to satisfy the requirements of performance class A 1 of the characteristic reaction to fire, in accordance with the provisions of the EC Decision 96/603/EC (as amended) without the need for testing on the basis of its listing in that decision.

Concerning Essential Requirements No. 1 (Mechanical resistance and stability) and No. 4 (Safety in use) the following applies:

The characteristic values of resistance given in Annex 3 were determined by tests with every fastening tool (as far as necessary).

The factor α_{cycl} given in Annex 3 considers in accordance with EN 1993-1-3 the effect of repeated wind loads on design tension strength. The design tension strength of the fasteners is based on static as well as on cyclic tests resulting in a factor $\alpha_{cycl} = 1.0$.

The formulas to calculate the design resistance are given in Annex 3.

3 Evaluation and attestation of conformity and CE marking

3.1 System of attestation of conformity

According to the Decision 99/92/EC of the European Commission⁹ system 2+ of the attestation of conformity applies.

This system of attestation of conformity is defined as follows:

System 2+: Declaration of conformity of the product by the manufacturer on the basis of:

(a) Tasks for the manufacturer:

- (1) initial type-testing of the product;
- (2) factory production control;
- (3) testing of samples taken at the factory in accordance with a prescribed test plan.

⁸ The technical documentation to this European Technical Approval is deposited at Deutsches Institut für Bautechnik and, as far as relevant for the tasks of the approved bodies involved in the attestation of conformity procedure is handed over to the approved bodies.

⁹ Official Journal of the European Communities L 80 of 18.03.1998

(b) Tasks for the approved body:

(4) certification of factory production control on the basis of:

- initial inspection of factory and of factory production control;
- continuous surveillance, assessment and approval of factory production control.

Note: Approved bodies are also referred to as "notified bodies".

3.2 Responsibilities

3.2.1 Tasks for the manufacturer

3.2.1.1 Factory production control

The manufacturer shall exercise permanent internal control of production. All the elements, requirements and provisions adopted by the manufacturer shall be documented in a systematic manner in the form of written policies and procedures, including records of results performed. This production control system shall insure that the product is in conformity with this European technical approval.

The manufacturer may only use initial materials stated in the technical documentation of this European technical approval.

The factory production control shall be in accordance with the control plan of February 2008 relating to the European technical approval ETA - 08/0040 issued on 6 March 2008 which is part of the technical documentation of this European technical approval. The control plan is laid down in the context of the factory production control system operated by the manufacturer and deposited with Deutsches Institut für Bautechnik.¹⁰

The results of factory production control shall be recorded and evaluated in accordance with the provisions of the control plan.

3.2.1.2 Other tasks for the manufacturer

The manufacturer shall, on the basis of a contract, involve a body which is approved for the tasks referred to in section 3.1 in the field of powder actuated fasteners in order to undertake the actions laid down in section 3.2.2 For this purpose, the control plan referred to in sections 3.2.1.1 and 3.2.2 shall be handed over by the manufacturer to the approved body involved.

The manufacturer shall make a declaration of conformity, stating that the construction product is in conformity with the provisions of the European technical approval ETA - 08/0040 issued on 6 March 2008.

3.2.2 Tasks for the approved bodies

The approved body shall perform the

- initial inspection of factory and of factory production control,
- continuous surveillance, assessment and approval of factory production control

in accordance with the provisions laid down in the control plan.

The approved body shall retain the essential points of its actions referred to above and state the results obtained and conclusions drawn in written reports.

The approved certification body involved by the manufacturer shall issue an EC certificate of conformity of the factory production control stating the conformity with the provisions of this European technical approval.

In cases where the provisions of the European technical approval and its control plan are no longer fulfilled the certification body shall withdraw the certificate of conformity and inform Deutsches Institut für Bautechnik without delay.

¹⁰

The "control plan" is a confidential part of the European technical approval and only handed over to the approved bodies involved in the procedure of attestation of conformity. See section 3.2.2.

3.3 CE marking

The CE marking shall be affixed on each packaging of fasteners. The letters "CE" shall be followed by the identification number of the approved certification body, where relevant, and be accompanied by the following additional information:

- the name and address of the producer (legal entity responsible for the manufacture),
- the last two digits of the year in which the CE marking was affixed,
- the number of the EC certificate for the factory production control,
- the number of the European technical approval,
- the name of the product.

4 Assumptions under which the fitness of the product for the intended use was favourably assessed

4.1 Manufacturing

The fasteners are manufactured in accordance with the provisions of the European Technical Approval using the manufacturing process as laid down in the technical documentation.

The European technical approval is issued for the product on the basis of agreed data/information, deposited with Deutsches Institut für Bautechnik, which identifies the product that has been assessed and judged. Changes to the product or production process, which could result in this deposited data/information being incorrect, should be notified to Deutsches Institut für Bautechnik before the changes are introduced. Deutsches Institut für Bautechnik will decide whether or not such changes affect the approval and consequently the validity of the CE marking on the basis of the approval and if so whether further assessment or alterations to the approval shall be necessary.

4.2 Design

For the types of connection (a, b, c, d) listed in Annex 2 and Annex 3 it is not necessary to take into account the effect of constraints due to temperature for the steel grades S280 and S320 in accordance with EN 10326:2004. For the steel grade S350 in accordance with EN 10326:2004 it shall be considered for design.

The loading is predominantly static. (Remark: Wind loads are regarded as predominantly static.)

Dimensions, material properties, application limits and nail head standoff as stated in the ETA are observed.

The verification concept stated in EN 1990 is used for the design of the connections made with the fasteners. The characteristic values (shear and tension resistance) stated in Annex 3 are used for the design of the entire connections.

The partial safety factor $\gamma_M = 1.25$ is used in order to determine the corresponding design resistances, provided no values are given in national regulations of the member state in which the fastener is used or in the respective National Annex to Eurocode 3.

In case of combined tension and shear forces the linear interaction formula according to EN 1993-1-3:2006, section 8.3 (8) is taken into account.

The possibly required reduction of the tension resistance due to the position of the fastener is taken into account in accordance with EN 1993-1-3:2006, section 8.3 (7) and Fig. 8.2.

4.3 Installation

The installation is carried out such that the fasteners are replaceable if necessary.

The installation is only carried out according to the manufacturer's instructions. The manufacturer hands over the assembly instructions to the assembler.

Cartridge selection in order to cover the application limit diagram is taken into account as given in Annex 3.

Installation safety tests are carried out, provided the fitness of the recommended cartridge cannot be checked otherwise (e.g. check of nail head standoff).

The nail head standoff (NHS) is in accordance with the requirements given in Annex 3.

The conformity of the installed fasteners with the provisions of the ETA is attested by the executing company.

5 Indications to the manufacturer

It is in the responsibility of the manufacturer to ensure that the information on the specific conditions according to 1, 2, 4.2 and 4.3 (including Annexes referred to) is given to those who are concerned. This information may be given by reproduction of the respective parts of the European technical approval. In addition all installation data (minimum / maximum nail head standoff, application limits in accordance with Annex 3) shall be shown clearly on the package and/or on an enclosed instruction sheet, preferably using illustration(s).

In Vertretung
G. Breitschaft
Berlin, 6 March 2008

beglaubigt
Ulbrich

Powder-actuated fastener / Cartridge fired pin

Material: Pin Steel Ck60 (1.1221) quenched and tempered, galvanised
 Washer Steel Ck35 (1.1181) galvanised

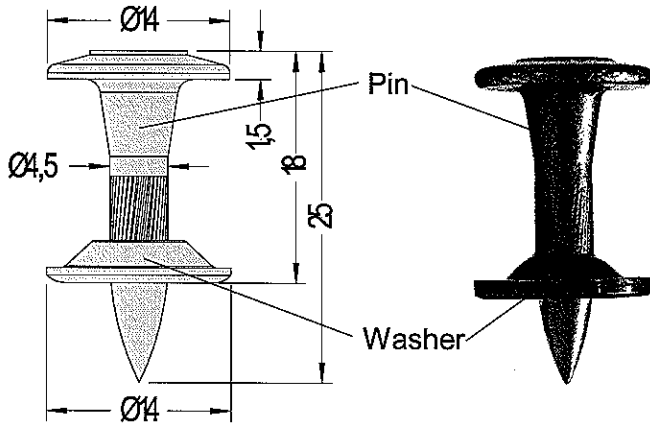

Cartridge K 6.3 / 16

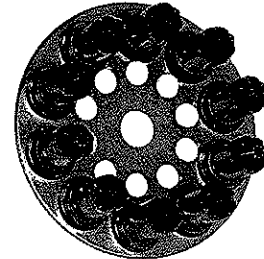

Blue: Medium load
 Red: Medium high load
 Black: Extra high load (see above)

Powder-actuated fastening tools

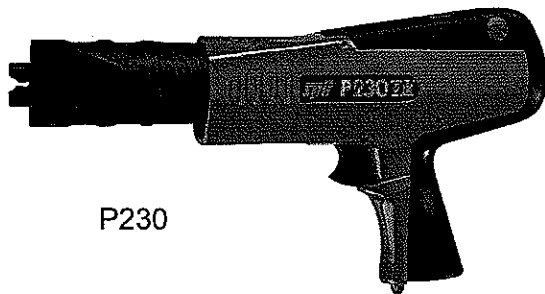

P230

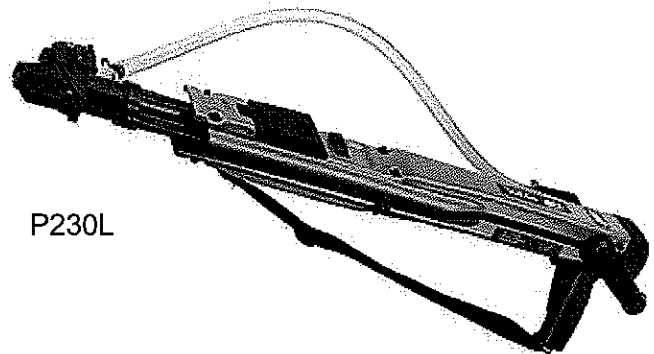

P230L

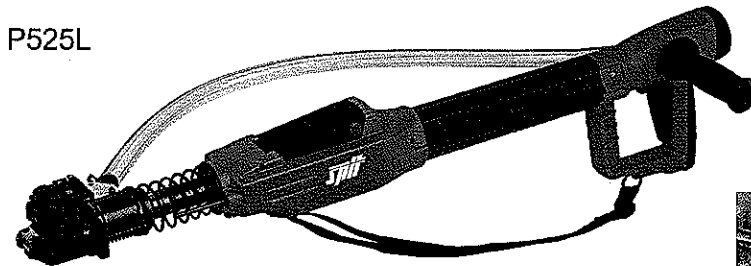



P525L



Sample for application

Powder actuated fastener	Annex 1 to European technical approval ETA – 08/0040
Fastener and corresponding fastening tools	

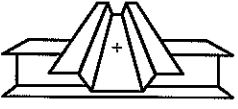
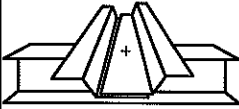
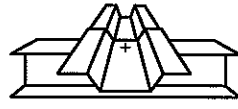
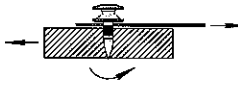
Types of connection and corresponding loading conditions

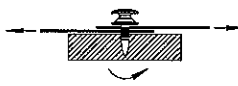
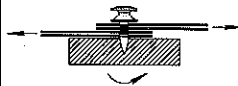
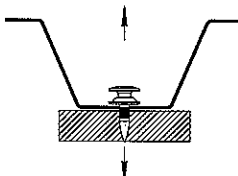
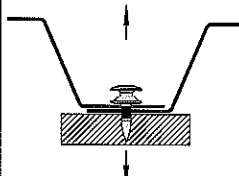
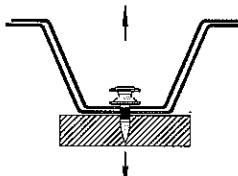
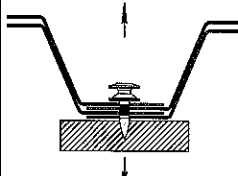
	Types of connection			
	Type a	Type b	Type c	Type d
				
Type of loading	Single connection	Side lap connection	End overlap connection	Side lap + end overlap connection
Shear loading				
Tension loading				

Powder actuated fastener

Types of connection

Annex 2

to European Technical Approval

ETA – 08/0040

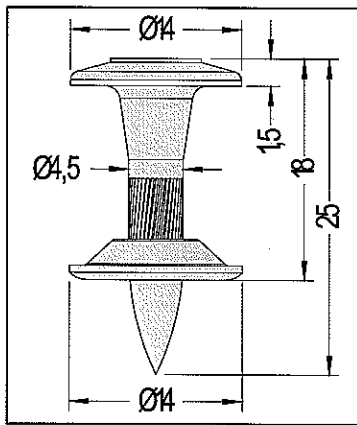

Powder-actuated fastener and fastening tools:

HSBR-14 with: **P230, P230L or P525L**

Cartridges: **K 6.3 / 16 - Blue, K 6.3 / 16 - Red, K 6.3 / 16 - Black**

Installation control:

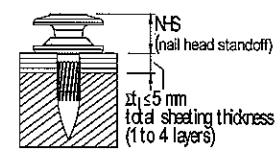
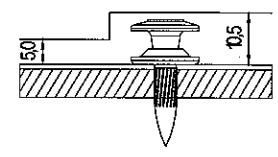

$5 \text{ mm} \leq \text{NHS} \leq 11.5 \text{ mm} - \Sigma t_i$

Characteristic shear and tension resistance V_{Rk} and N_{Rk}			
sheeting thickness t_i [mm]	Shear V_{Rk} [kN]	Tension N_{Rk} [kN]	Types of connection
0.63	4.2	5.3	a,b,c,d
0.75	5.8	6.6	a,b,c,d
0.88	7.5	7.7	a,b,c,d
1.00	8.6	8.2	a,b,c,d
1.13	9.1	9.1	a,c
1.25	9.5	9.5	a,c
1.50	10.0	10.0	a
1.75	10.0	10.1	a
2.00	10.0	10.3	a
2.50	10.0	10.4	a
3.00	10.0	10.5	a

Design shear and tension resistance V_{Rd} and N_{Rd}	
$V_{Rd} = V_{Rk} / \gamma_M$ $\gamma_M = 1.25$ in the absence of national regulations	$N_{Rd} = \alpha_{cycl} N_{Rk} / \gamma_M$ $\alpha_{cycl} = 1.0$ α_{cycl} considers the effect of repeated wind loads $\alpha_{cycl} = 1.0$ for all sheeting thickness t_i $\gamma_M = 1.25$ in the absence of national regulations

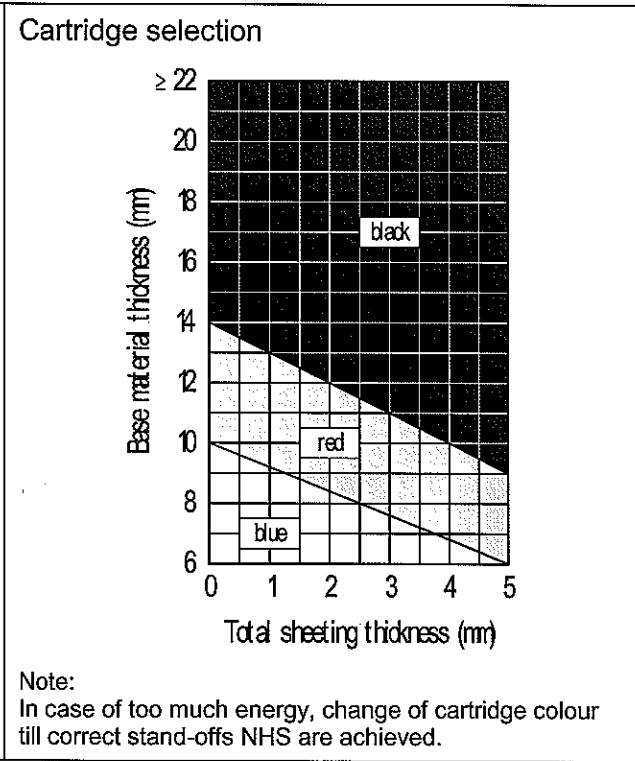
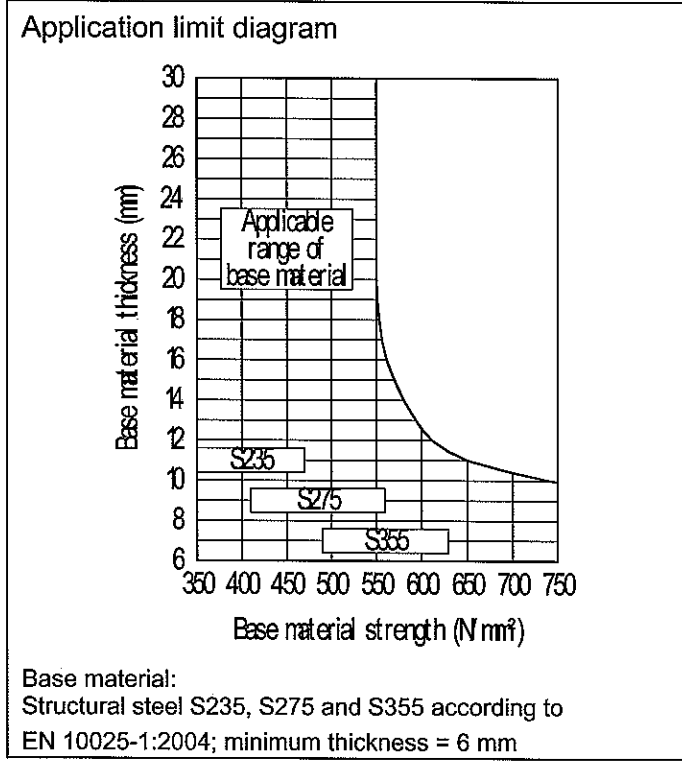

Powder actuated fastener

HSBR-14 with tools P230, P230L and P525L:
 Characteristic and design resistance, application limit,
 cartridge selection and nail head standoff

Annex 3
 to European technical approval
ETA - 08/0040