

**ANNEXE C :****Design methods for anchorages**

Introduction .....	2	5 Ultimate limit state .....	11
1 Scope .....	3	5.1 General .....	11
1.1 Type of anchors, anchor groups and number of anchors .....	3	5.2 Design method A .....	11
1.2 Concrete member .....	3	5.2.1 General .....	11
1.3 Type and direction of load .....	3	5.2.2 Resistance to tension loads .....	11
1.4 Safety class .....	3	5.2.2.1 Required proofs .....	11
2 Terminology and Symbols .....	4	5.2.2.2 Steel failure .....	11
2.1 Indices .....	4	5.2.2.3 Pull-out failure .....	11
2.2 Actions and resistances .....	4	5.2.2.4 Concrete cone failure .....	12
2.3 Concrete and steel .....	4	5.2.2.5 Splitting failure due to anchor installation .....	12
2.4 Characteristic values of anchors .....	4	5.2.2.6 Splitting failure due to loading .....	13
3 Design and safety concept .....	5	5.2.3 Resistance to shear loads .....	14
3.1 General .....	5	5.2.3.1 Required proofs .....	14
3.2 Ultimate limit state .....	6	5.2.3.2 Steel failure .....	14
3.2.1 Partial safety factors for actions .....	6	5.2.3.3 Concrete pryout failure .....	14
3.2.2 Design resistance .....	6	5.2.3.4 Concrete edge failure .....	15
3.2.3 Partial safety factors for resistances .....	6	5.2.4 Résistance à des charges combinées de traction et de cisaillement .....	17
3.2.3.1 Concrete cone failure, splitting failure and pull-out failure .....	6	5.3 Design method B .....	17
3.2.3.2 Steel failure .....	6	5.4 Design method C .....	18
3.3 Serviceability limit state .....	7	6 Serviceability limit state .....	18
4 Static analysis .....	7	6.1 Displacements .....	18
4.1 Non-cracked and cracked concrete .....	7	6.2 Shear load with changing sign .....	18
4.2 Loads acting on anchors .....	7	7 Additional proofs for ensuring the characteristic resistance of concrete member .....	18
4.2.1 Tension loads .....	7	7.1 General .....	18
4.2.2 Shear loads .....	8	7.2 Shear resistance of concrete member ...	18
4.2.2.1 Distribution of shear loads .....	8	7.3 Resistance to splitting forces .....	19
4.2.2.2 Shear loads without lever arm .....	10		
4.2.2.3 Shear loads with lever arm .....	10		

---

## ***Introduction***

---

The design methods for anchorages are intended to be used for the design of anchorages under due consideration of the safety and design concept within the scope of the European Technical Approvals (ETA) of anchors.

The design methods given in Annex C are based on the assumption that the required tests for assessing the admissible service conditions given in Part 1 and the subsequent Parts have been carried out. Therefore Annex C is a pre-condition for assessing and judging of anchors. The use of other design methods will require reconsideration of the necessary tests.

The ETA's for anchors give the characteristic values only of the different approved anchors. The design of the anchorages (e.g. arrangement of anchors in a group of anchors, effect of edges or corners of the concrete member on the characteristic resistance) shall be carried out according to the design methods described in Chapter 3 to 5 taking account of the corresponding characteristic values of the anchors.

Chapter 7 gives additional proofs for ensuring the characteristic resistance of the concrete member which are valid for all anchor systems.

The design methods are valid for all anchor types. However, the equations given in the following are valid for anchors according to current experience only (see Annex B). If values for the characteristic resistance, spacings, edge distances and partial safety factors differ between the design methods and the ETA, the value given in the ETA governs. In the absence of national regulations the partial safety factors given in the following may be used.

# 1 Scope

## 1.1 Type of anchors, anchor groups and number of anchors

The design methods apply to the design of anchorages in concrete using approved anchors which fulfill the requirements of this Guideline. The characteristic values of these anchors are given in the relevant ETA.

The design methods are valid for single anchors and anchor groups. In case of an anchor group the loads are applied to the individual anchors of the group by means of a rigid fixture. In an anchor group only anchors of the same type, size and length shall be used.

The design methods cover single anchors and anchor groups according to Figure 1.1 and 1.2. Other anchor arrangements e.g. in a triangular or circular pattern are also allowed; however, the provisions of this design method should be applied with engineering judgement. Figure 1.1 is only valid if the edge distance in all directions is greater than or equal to  $10 h_{ef}$ .

## 1.2 Concrete member

The concrete member shall be of normal weight concrete of at least strength class C 20/25 and at most strength class C 50/60 to ENV 206 [8] and shall be subjected only to predominantly static loads. The concrete may be cracked or non-cracked. In general for simplification it is assumed that the concrete is cracked; otherwise it shall be shown that the concrete is non-cracked (see 4.1).

## 1.3 Type and direction of load

The design methods apply to anchors subjected to static or quasi-static loadings and not to anchors subjected to impact or seismic loadings or loaded in compression.

## 1.4 Safety class

Anchorage carried out in accordance with these design methods are considered to belong to anchorages, the failure of which would cause risk to human life and/or considerable economic consequences.

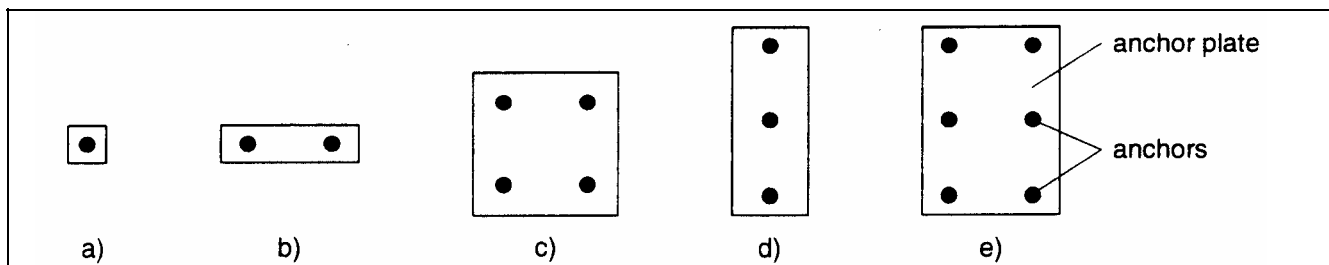

Figure 1.1 - Anchorages situated far from edges ( $c \geq 10 h_{ef}$ ) covered by the design methods

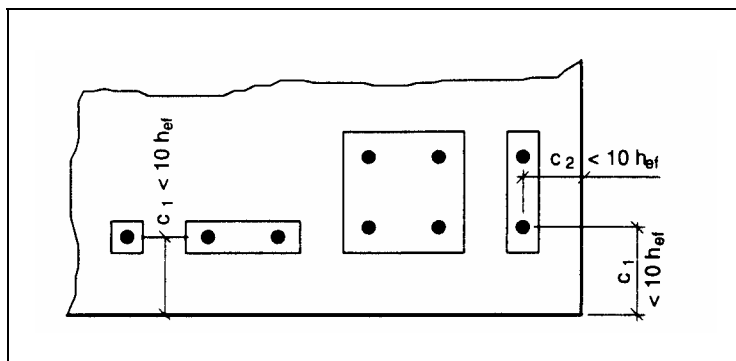

Figure 1.2  
situated near to an edge ( $c < 10 h_{ef}$ )  
covered by the design methods

## 2 Terminology and Symbols

The notations and symbols frequently used in the design methods are given below. Further notations are given in the text.

### 2.1 Indices

S	=	action
R	=	resistance
M	=	material
k	=	characteristic value
d	=	design value
s	=	steel
c	=	concrete
cp	=	concrete pryout
p	=	pull-out
sp	=	splitting
u	=	ultimate
y	=	yield

### 2.2 Actions et resistances

F	=	force in general (resulting force)
N	=	normal force (positiv: tension force, negativ: compression force)
V	=	shear force
M	=	moment
$F_{Sk} (N_{Sk}; V_{Sk}; M_{Sk}; M_{T,Sk})$	=	characteristic value of actions acting on a single anchor or the fixture of an anchor group respectively (normal load, shear load, bending moment, torsion moment)
$F_{Sd} (N_{Sd}; V_{Sd}; M_{Sd}; M_{T,Sd})$	=	design value of actions acting on a single anchor or the fixture of an anchor group respectively (normal load, shear load, bending moment, torsion moment)
$N_{Sd}^h (V_{Sd}^h)$	=	design value of tensile load (shear load) acting on the most stressed anchor of an anchor group calculated according to 4.2
$N_{Sd}^g (V_{Sd}^g)$	=	design value of the sum (resultant) of the tensile (shear) loads acting on the tensioned (sheared) anchors of a group calculated according to 4.2
$F_{Rk} (N_{Rk}; V_{Rk})$	=	characteristic value of resistance of a single anchor or an anchor group respectively (normal force, shear force)
$F_{Rd} (N_{Rd}; V_{Rd})$	=	design value of resistance of a single anchor or an anchor group respectively (normal force, shear force)

### 2.3 Concrete and steel

$F_{ck,cube}$	=	characteristic concrete compression strength measured on cubes with a side length of 150 mm (value of concrete strength class according to ENV 206 [8])
$f_{yk}$	=	characteristic steel yield strength (nominal value)
$f_{uk}$	=	characteristic steel ultimate tensile strength (nominal value)
$A_S$	=	stressed cross section of steel
$W_{el}$	=	elastic section modulus calculated from the stressed cross section of steel ( $\frac{\pi d^3}{32}$ for a round section with diameter d)

### 2.4 Characteristic values of anchors (see Figure 2.1)

a	=	spacing between outer anchors of adjoining groups or between single anchors
$a_1$	=	spacing between outer anchors of adjoining groups or between single anchors in direction 1
$a_2$	=	spacing between outer anchors of adjoining groups or between single anchors in direction 2
b	=	width of concrete member
c	=	edge distance
$c_1$	=	edge distance in direction 1; in case of anchorages close to an edge loaded in shear $c_1$ is the edge distance in direction of the shear load (see Figure 2.1b and Figure 5.7)
$c_2$	=	edge distance in direction 2; direction 2 is perpendicular to direction 1
$c_{cr}$	=	edge distance for ensuring the transmission of the characteristic resistance (design methods B and C)
$c_{cr,N}$	=	edge distance for ensuring the transmission of the characteristic tensile resistance of a single anchor without spacing and edge effects in case of concrete cone failure (design method A)

$c_{cr,sp}$  = edge distance for ensuring the transmission of the characteristic tensile resistance of a single anchor without spacing and edge effects in case of splitting failure (design method A)  
 $c_{min}$  = minimum allowable edge distance  
 $d$  = diameter of anchor bolt or thread diameter  
 $d_{nom}$  = outside diameter of anchor  
 $d_o$  = drill hole diameter  
 $h$  = thickness of concrete member  
 $h_{ef}$  = effective anchorage depth  
 $h_{min}$  = minimum thickness of concrete member  
 $l_f$  = effective length of anchor under shear loading. For bolts of uniform cross-section over their lengths the value of  $h_{ef}$  has to be used as effective anchorage depth, and for anchors with several sleeves and throats of cross-section, for example, only the length from the concrete surface up to the relevant sleeve would govern.  
 $s$  = spacing of anchors in a group  
 $s_1$  = spacing of anchors in a group in direction 1  
 $s_2$  = spacing of anchors in a group in direction 2  
 $s_{cr}$  = spacing for ensuring the transmission of the characteristic resistance (design methods B and C)

$s_{cr,N}$  = spacing for ensuring the transmission of the characteristic tensile resistance of a single anchor without spacing and edge effects in case of concrete cone failure (design method A)  
 $s_{cr,sp}$  = spacing for ensuring the transmission of the characteristic tensile resistance of a single anchor without spacing and edge effects in case of splitting failure (design method A)  
 $s_{min}$  = minimum allowable spacing

## 3 Design and safety concept

### 3.1 General

For the design of anchorages the safety concept of partial safety factors shall be applied. It shall be shown that the value of the design actions  $S_d$  does not exceed the value of the design resistance  $R_d$ .

$$S_d \leq R_d \quad (3.1)$$

$S_d$  = value of design action

$R_d$  = value of design resistance

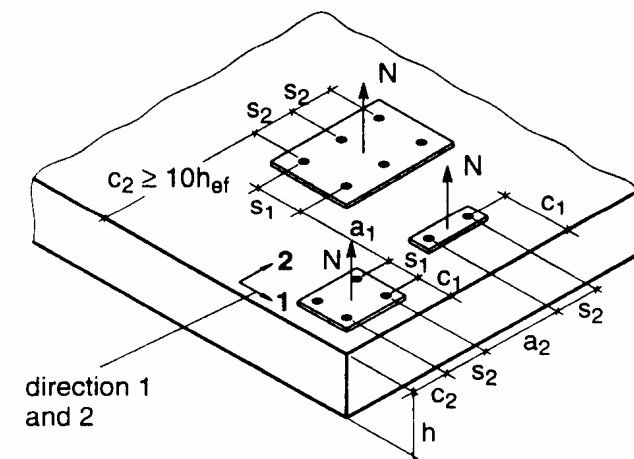

a) anchors subjected to tension load

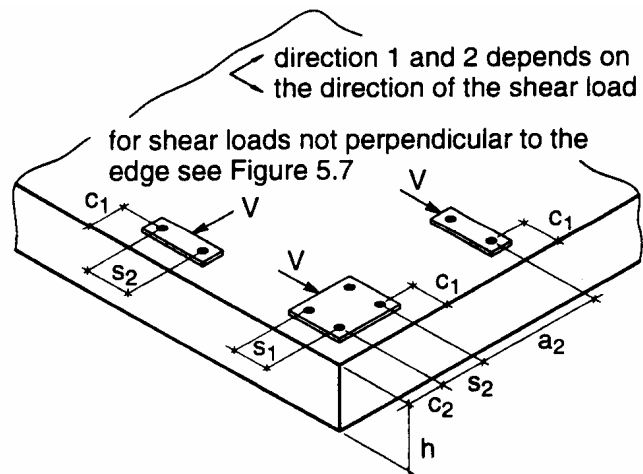

b) anchors subjected to shear load in case of anchorage near to an edge

Figure 2.1  
Concrete member, anchor spacing and edge distance

In the absence of national regulations the design actions in the ultimate limit state or serviceability limit state respectively shall be calculated according to Eurocode 2 [1] or Eurocode 3 [14].

*In the simplest case (permanent load and one variable load acting in one direction) the following equation applies:*

$$S_d = \gamma_G \cdot G_k + \gamma_Q \cdot Q_k \quad (3.2)$$

$G_k$  ( $Q_k$ ) = characteristic value of a permanent (variable) action

$\gamma_G$  ( $\gamma_Q$ ) = partial safety factor for permanent (variable) action

The design resistance is calculated as follows:

$$R_d = R_k / \gamma_M \quad (3.3)$$

$R_k$  = characteristic resistance of a single anchor or an anchor group

$\gamma_M$  = partial safety factor for material

## 3.2 Ultimate limit state

### 3.2.1 Partial safety factors for actions

The partial safety factors for actions depend on the type of loading and shall be taken from national regulations or, in the absence of them, from [1] or [14]. In Equation (3.2) the partial safety factor according to [1] is  $\gamma_G = 1.35$  for permanent actions and  $\gamma_Q = 1.5$  for variable actions.

### 3.2.2 Design resistance

The design resistance is calculated according to Equation (3.3). In design method A the characteristic resistance is calculated for all load directions and failure modes.

In design methods B und C only one characteristic resistance is given for all load directions and failure modes.

### 3.2.3 Partial safety factors for resistances

In the absence of national regulations the following partial safety factors may be used. However, the value of  $\gamma_2$  may not be changed because it describes a characteristic of the anchors.

#### 3.2.3.1 Concrete cone failure, splitting failure and pull-out failure

The partial safety factors for concrete cone failure ( $\gamma_{Mc}$ ), splitting failure ( $\gamma_{Msp}$ ) and pull-out failure ( $\gamma_{Mp}$ ) are given in the relevant ETA.

They are valid only if after installation the actual dimensions of the effective anchorage depth, spacing and edge distance are not less than the design values (only positive tolerances allowed).

*For anchors to according current experience the partial safety factor  $\gamma_{Mc}$  is determined from:*

$$\gamma_{Mc} = \gamma_c \cdot \gamma_1 \cdot \gamma_2$$

$\gamma_c$  = partial safety factor for concrete under compression = 1.5

$\gamma_1$  = partial safety factor taking account of the scatter of the tensile strength of site concrete 1.2 for concrete produced and cured with normal care

$\gamma_2$  = partial safety factor taking account of the installation safety of an anchor system  
The partial safety factor  $\gamma_2$  is evaluated from the results of the installation safety tests, see Part 1, 6.1.2.2.2.

*Tension loading*

$\gamma_2$  = 1.0 for systems with high installation safety  
= 1.2 for systems with normal installation safety  
= 1.4 for systems with low but still acceptable installation safety

*Shear loading*

$$\gamma_2 = 1.0$$

*For the partial safety factors  $\gamma_{Msp}$  and  $\gamma_{Mp}$  the value for  $\gamma_{Mc}$  may be taken.*

#### 3.2.3.2 Steel failure

The partial safety factors  $\gamma_{Ms}$  for steel failure are given in the relevant ETA.

*For anchors according to current experience the partial safety factors  $\gamma_{Ms}$  are determined as a function of the type of loading as follows:*

$$\text{Tension loading: } \gamma_{Ms} = \frac{1.2}{f_{yk} / f_{uk}} \geq 1.4 \quad (3.5a)$$

Shear loading of the anchor with and without lever arm:

$$\gamma_{Ms} = \frac{1.0}{f_{yk}/f_{uk}} \geq 1.25 \quad f_{uk} \leq 800 \text{ N/mm}^2 \quad (3.5b)$$

$$\text{and } f_{yk}/f_{uk} \leq 0.8$$

$$\gamma_{Ms} = 1.5 \quad f_{uk} > 800 \text{ N/mm}^2 \quad (3.5c)$$

$$\text{or } f_{yk}/f_{uk} > 0.8$$

### 3.3 Serviceability limit state

In the serviceability limit state it shall be shown that the displacements occurring under the characteristic actions are not larger than the admissible displacement. For the characteristic displacements see 6. The admissible displacement depends on the application in question and should be evaluated by the designer.

In this check the partial safety factors on actions and on resistances may be assumed to be equal to 1.0.

## 4 Static analysis

### 4.1 Non-cracked and cracked concrete

If the condition in Equation (4.1) is not fulfilled or not checked, then cracked concrete shall be assumed.

Non-cracked concrete may be assumed in special cases if in each case it is proved that under service conditions the anchor with its entire anchorage depth is located in non-cracked concrete. In the absence of other guidance the following provisions may be taken.

For anchorages subjected to a resultant load  $F_{Sk} < 60 \text{ kN}$  non-cracked concrete may be assumed if Equation (4.1) is observed:

$$\sigma_L + \sigma_R \leq 0 \quad (4.1)$$

$\sigma_L$  = stresses in the concrete induced by external loads, including anchors loads

$\sigma_R$  = stresses in the concrete due to restraint of intrinsic imposed deformations (e.g. shrinkage of concrete) or extrinsic imposed deformations (e.g. due to displacement of support or temperature variations). If no detailed analysis is conducted, then  $\sigma_R = 3 \text{ N/mm}^2$  should be assumed, according to EC 2 [1].

The stresses  $\sigma_L$  and  $\sigma_R$  shall be calculated assuming that the concrete is non-cracked (state I). For plane concrete members which transmit loads in two directions (e.g. slabs, walls) Equation (4.1) shall be fulfilled for both directions.

### 4.2 Loads acting on anchors

In the static analysis the loads and moments are given which are acting on the fixture. To design the anchorage the loads acting on each anchor shall be calculated, taking into account partial safety factors for actions according to 3.2.1 in the ultimate limit state and according to 3.3 in the serviceability limit state.

With single anchors normally the loads acting on the anchor are equal to the loads acting on the fixture. With anchor groups the loads, bending and torsion moments acting on the fixture shall be distributed to tension and shear forces acting on the individual anchors of the group. This distribution shall be calculated according to the theory of elasticity.

#### 4.2.1 Tension loads

In general, the tension loads acting on each anchor due to loads and bending moments acting on the fixture shall be calculated according to the theory of elasticity using the following assumptions:

- The anchor plate does not deform under the design actions. To ensure the validity of this assumption the anchor plate shall be sufficiently stiff and its design should be carried out according to standards for steel structures ensuring elastic behaviour.
- The stiffness of all anchors is equal and corresponds to the modulus of elasticity of the steel. The modulus of elasticity of concrete is given in [1]. As a simplification it may be taken as  $E_c = 30\,000 \text{ N/mm}^2$ .
- In the zone of compression under the fixture the anchors do not contribute to the transmission of normal forces (see Figure 4.1b).

If in special cases the anchor plate is not sufficiently stiff, then the flexibility of the anchor plate should be taken into account when calculating loads acting on the anchors.

In the case of anchor groups with different levels of tension forces  $N_{si}$  acting on the individual anchors of a group the eccentricity  $e_N$  of the tension force  $N_S^g$  of the group may be calculated (see Figure 4.1), to enable a more accurate assessment of the anchor group resistance.

If the tensioned anchors do not form a rectangular pattern, for reasons of simplicity the group of tensioned anchors may be resolved into a group rectangular in shape (that means the centre of gravity of the tensioned anchors may be assumed in the center of the axis in Figure 4.1c).

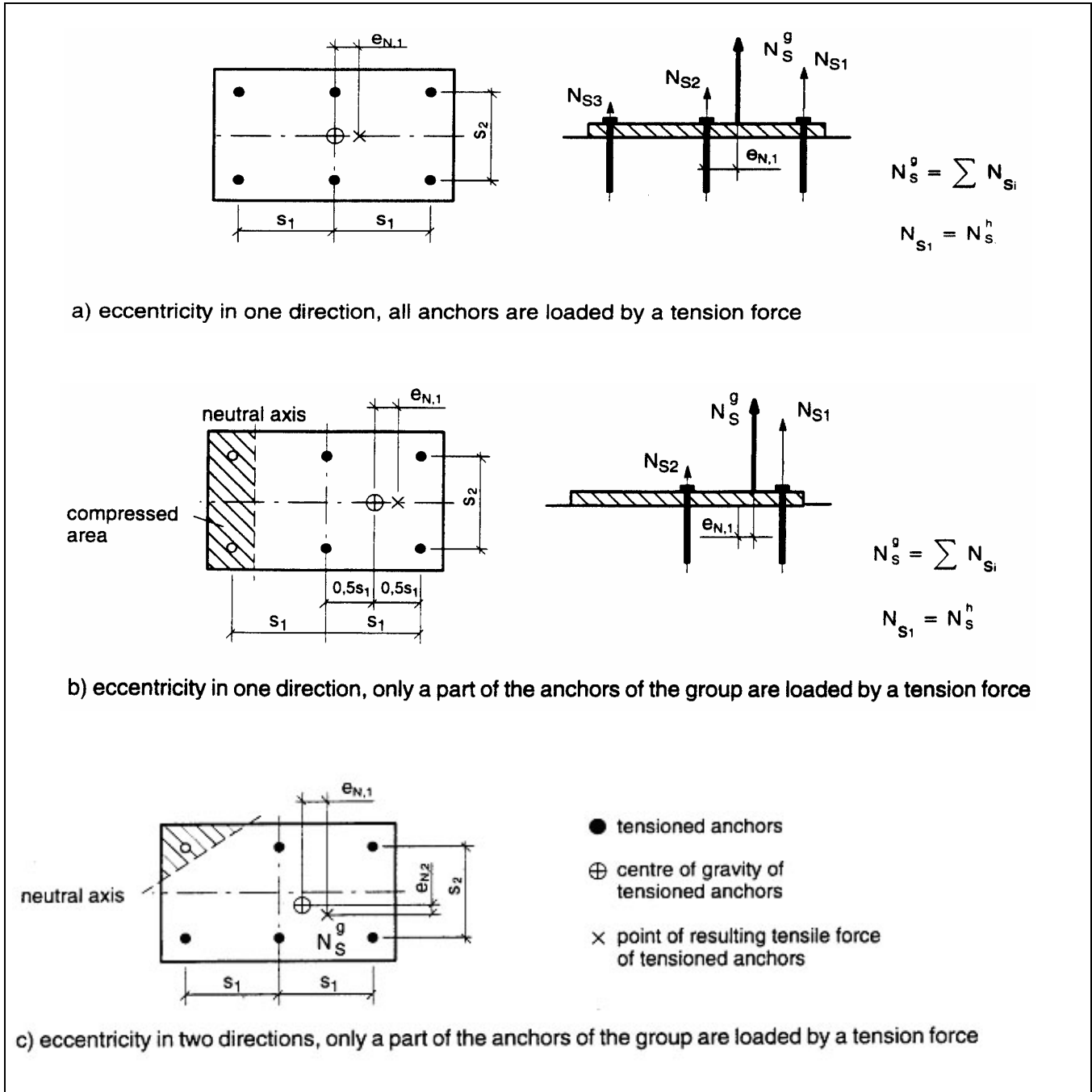

Figure 4.1 - Example of anchorages subjected to an eccentric tensile load  $N_s^g$

## 4.2.2 Shear loads

### 4.2.2.1 Distribution of loads

For the distribution of shear loads and torsion moments acting on the fixture to the anchors of a group the following cases shall be distinguished:

a) All anchors take up shear loads if the hole clearance is not greater than given in Table 4.1 and the edge distance is larger than  $10 h_{ef}$  (see Figure 4.2 a-c).

b) Only the most unfavourable anchors take up shear loads if the edge distance is smaller than  $10 h_{ef}$  (independent of the hole clearance) (see Figure 4.3 a-c) or the hole clearance is larger than the values given in Table 4.1 (independent of the edge distance) (see Figure 4.4 a and b).

c) Slotted holes in direction of the shear load prevent anchors to take up shear loads. This can be favourable in case of anchorages close to an edge (see Figure 4.5).



**Tableau 4.1**  
**Diameter of clearance hole in the fixture**

external diameter $d$ (1) or $d_{nom}$ (2) (mm)	6	8	10	12	14	16	18	20	22	24	27	30
diameter $d_f$ of clearance hole in the fixture (mm)	7	9	12	14	16	18	20	22	24	26	30	33

1. if bolt bears against the fixture  
2. if sleeve bears against the fixture

In the case of anchor groups with different levels of shear forces  $V_{si}$  acting on the individual anchors of the group the of the  $V_S^g$  eccentricity  $e_v$ , of the shear force group may be calculated (see Figure 4.6), to enable a more accurate assessment of the anchor group resistance.

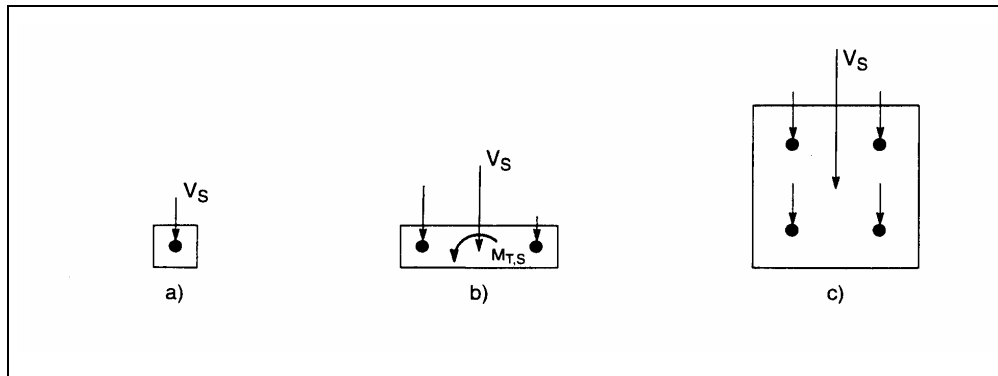

**Figure 4.2**  
**Examples of load distribution, when all anchors take up shear loads**

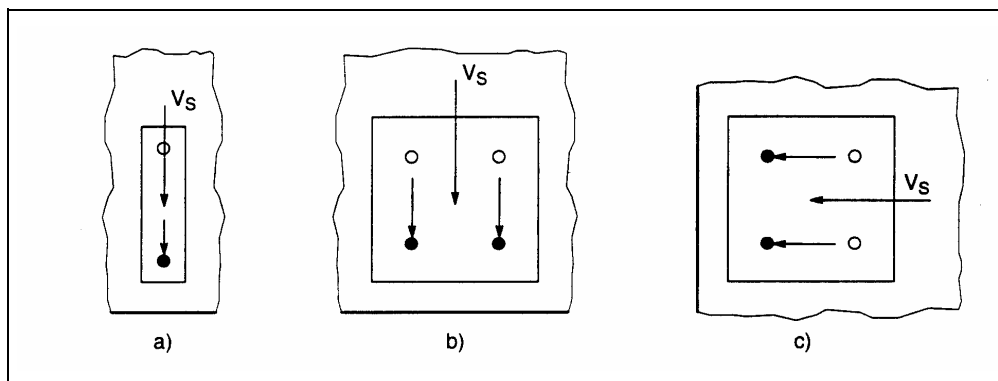

**Figure 4.3**  
**Examples of load distribution for anchorages close to an edge**

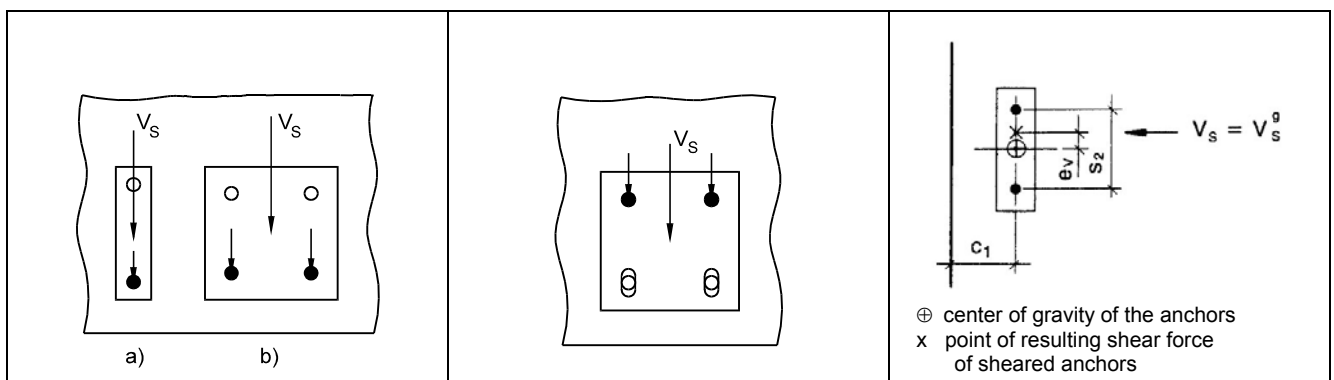

**Figure 4.4**  
**Examples of load distribution if the hole clearance is larger than the value according to Table 4.1**

**Figure 4.5**  
**Examples of load distribution for an anchorage with slotted holes**

**Figure 4.6**  
**Example of an anchorage subjected to an eccentric shear load**

4.2.2.2 Shear loads without lever arm

Shear loads acting on anchors may be assumed to act without lever arm if both of the following conditions are fulfilled:

- a) The fixture shall be made of metal and in the area of the anchorage be fixed directly to the concrete either without an intermediate layer or with a levelling layer of mortar with a thickness < 3 mm.
- b) The fixture shall be in contact with the anchor over its entire thickness.

4.2.2.3 Shear loads with lever arm

If the conditions a) and b) of 4.2.2.2 are not fulfilled the lever arm is calculated according to Equation (4.2) (see Figure 4.7)

$$l = a_3 + e_1 \quad (4.2)$$

with

e1 = distance between shear load and concrete surface

a3 = 0.5 d

a3 = 0 if a washer and a nut is directly clamped to the concrete surface (see Figure 4.7b)

d = nominal diameter of the anchor bolt or thread diameter (see Figure 4.7a)

The design moment acting on the anchor is calculated according to Equation (4.3).

$$M_{Sd} = V_{Sd} \cdot \frac{l}{\alpha_M} \quad (4.3)$$

The value  $\alpha_M$  depends on the degree of restraint of the anchor at the side of the fixture of the application in question and shall be judged according to good engineering practice.

No restraint ( $\alpha_M = 1.0$ ) shall be assumed if the fixture can rotate freely (see Figure 4.8a). This assumption is always on the safe side.

Full restraint ( $\alpha_M = 2.0$ ) may be assumed only if the fixture cannot rotate (see Figure 4.8b) and the hole clearance in the fixture is smaller than the values given in Table 4.1 or the anchor is clamped to the fixture by nut and washer (see Figure 4.7). If restraint of the anchor is assumed the fixture shall be able to take up the restraint moment.

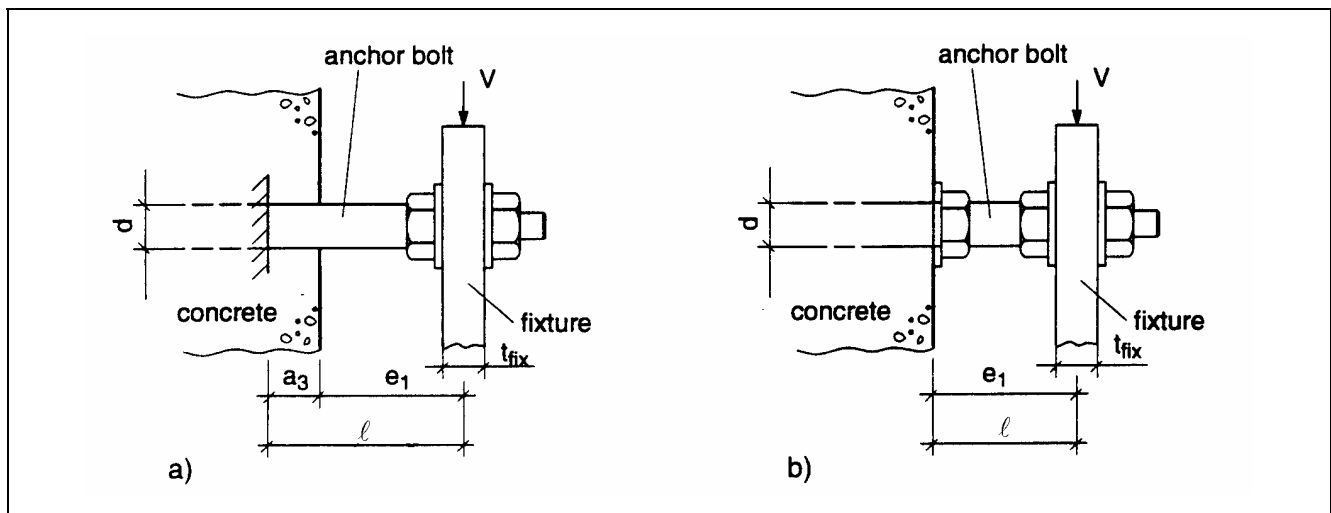

Figure 4.7 - Definition of lever arm



Figure 4.8 - Fixture without (a) and with (b) restraint

## 5 Ultimate limit state

### 5.1 General

For the design of anchorages in the ultimate limit state, there are three different design methods available. The linkage of the design methods and the required tests for admissible service conditions is given in Table 5.1. In 5.2 the general design method A is described; in 5.3 and 5.4 the simplified methods B and C are treated. The design method to be applied is given in the relevant ETA.

According to Equation (3.1) it shall be shown that the design value of the action is equal to or smaller than the design value of the resistance. The characteristic values of the anchor to be used for the calculation of the resistance in the ultimate limit state are given in the relevant ETA.

Spacing, edge distance as well as thickness of concrete member shall not remain under the given minimum values.

The spacing between outer anchor of adjoining groups or the distance to single anchors shall be  $a > s_{cr,N}$  (design method A) or  $s_{cr}$  respectively (design method B and C).

### 5.2 Design method A

#### 5.2.1 General

In design method A it shall be shown that Equation (3.1) is observed for all loading directions (tension, shear) as well as all failure modes (steel failure, pull-out failure and concrete failure).

In case of a combined tension and shear loading (oblique loading) the condition of interaction according to 5.2.4 shall be observed.

For Options 2 and 8 (see Part 1, Table 5.3),  $f_{ck, cube} = 25 \text{ N/mm}^2$  shall be inserted in Equations (5.2a) and (5.7a).

#### 5.2.2 Resistance to tension loads

##### 5.2.2.1 Required proofs

	single anchor	anchor group	
steel failure	$N_{Sd} \leq N_{Rk,s} / \gamma_{Ms}$	$N_{Sd}^h \leq N_{Rk,s} / \gamma_{Ms}$	
pull-out failure	$N_{Sd} \leq N_{Rk,p} / \gamma_{Mp}$	$N_{Sd}^h \leq N_{Rk,p} / \gamma_{Mp}$	
concrete cone failure	$N_{Sd} \leq N_{Rk,c} / \gamma_{Mc}$		$N_{Sd}^g \leq N_{Rk,c} / \gamma_{Mc}$
splitting failure	$N_{Sd} \leq N_{Rk,sp} / \gamma_{Msp}$		$N_{Sd}^g \leq N_{Rk,sp} / \gamma_{Msp}$

##### 5.2.2.2 Steel failure

The characteristic resistance of an anchor in case of steel failure,  $N_{Rk,s}$ , is given in the relevant ETA.

*The value of  $N_{Rk,s}$  is obtained from Equation (5.1)*

$$N_{Rk,s} = A_s \cdot f_{uk} [N] \quad (5.1)$$

##### 5.2.2.3 Pull-out failure

The characteristic resistance in case of failure by pull-out,  $N_{Rk,p}$ , shall be taken from the relevant ETA.

Tableau 5.1

Linkage of the design methods and the required tests for admissible service conditions

Design method	cracked and non-cracked concrete	non-cracked concrete only	characteristic resistance for		tests according Annex B Option
			C20/25 only	C20/25 to C50/60	
A	x			x	1
	x		x		2
		x		x	7
		x	x		8
B	x			x	3
	x		x		4
		x		x	9
		x	x		10
C	x			x	5
	x		x		6
		x		x	11
		x	x		12

5.2.2.4 Concrete cone failure

The characteristic resistance of an anchor or a group of anchors, respectively, in case of concrete cone failure is:

$$N_{Rk,c} = N_{Rk,c}^0 \cdot \frac{A_{c,N}}{A_{c,N}^0} \cdot \psi_{s,N} \cdot \psi_{re,N} \cdot \psi_{ec,N} \cdot \psi_{ucr,N} \quad [N] \quad (5.2)$$

The different factors of Equation (5.2) for anchors according to current experience are given below:

a) The initial value of the characteristic resistance of an anchor placed in cracked concrete is obtained by:

$$N_{Rk,c}^0 = 7.2 \cdot \sqrt{f_{ck,cube}} \cdot h_{ef}^{1.5} \quad [N] \quad (5.2a)$$

$f_{ck,cube}$  [N/mm<sup>2</sup>];  $h_{ef}$  [mm]

b) The geometric effect of spacing and edge distance on the characteristic resistance is taken into account by the value  $A_{c,N} / A_{c,N}^0$ , where:

$$\begin{aligned} A_{c,N}^0 &= \text{area of concrete of an individual anchor with large spacing and edge distance at the concrete surface, idealizing the concrete cone as a pyramid with a height equal to } h_{ef} \text{ and a base length equal } s_{cr,N} \text{ (see Figure 5.1)} \\ &= S_{cr,N} \cdot S_{cr,N} \end{aligned} \quad (5.2b)$$

$A_{c,N}$  = actual area of concrete cone of the anchorage at the concrete surface. It is limited by overlapping concrete cones of adjoining anchors ( $s \leq S_{cr,N}$ ) as well as by edges of the concrete member ( $c \leq C_{cr,N}$ ). Examples for the calculation of  $A_{c,N}$  are given in Figure 5.2.

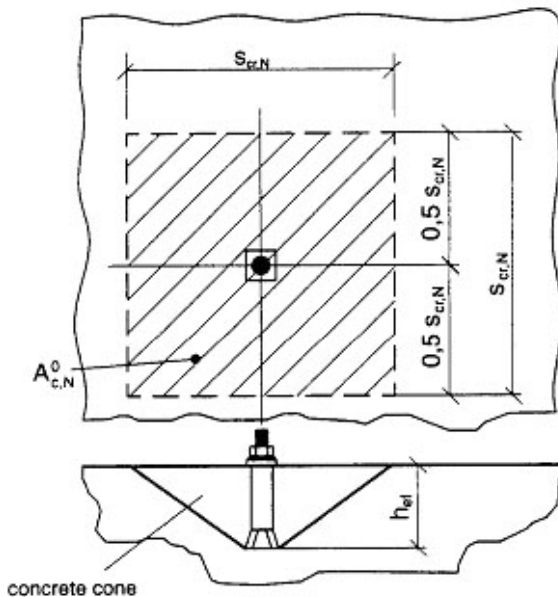

$$A_{c,N}^0 = S_{cr,N} \cdot S_{cr,N}$$

Figure 5.1 - Idealized concrete cone and area  $A_{c,N}^0$  of concrete cone of an individual anchor

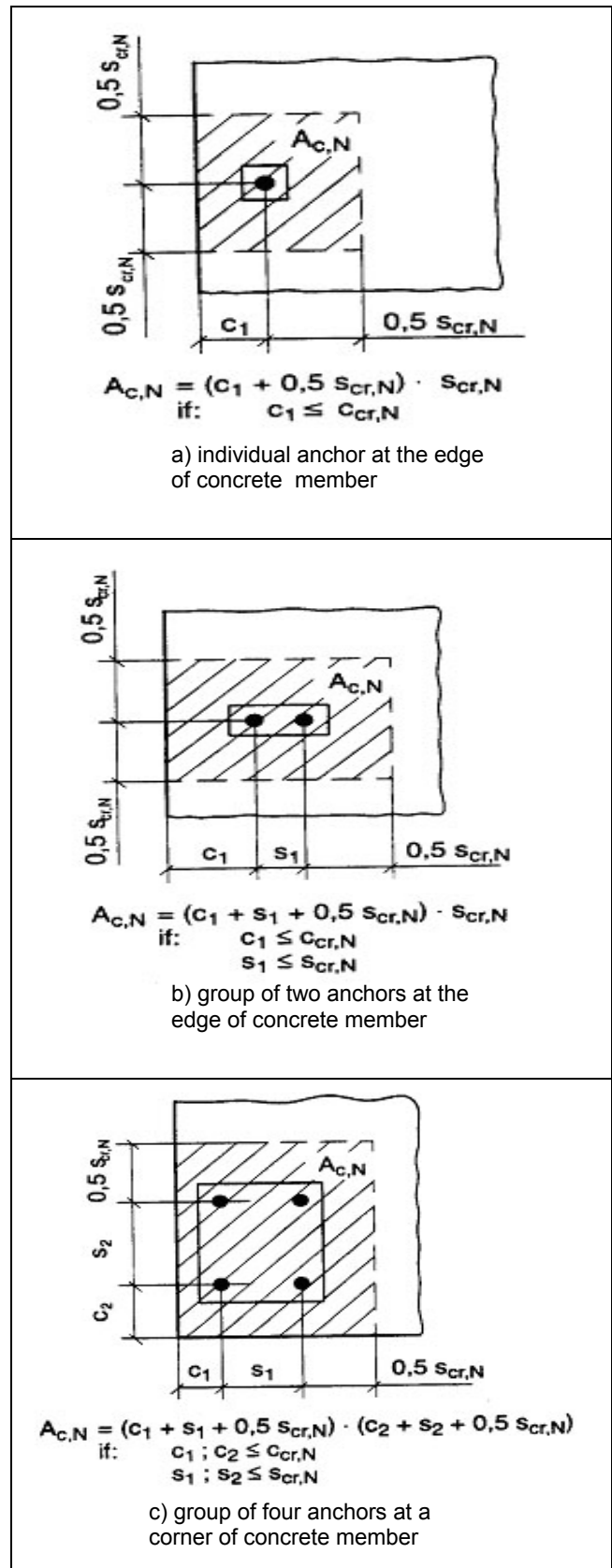

Figure 5.2 - Examples of actual areas  $A_{c,N}$  of the idealized concrete cones for different arrangements of anchors in the case of axial tension load

c) The factor  $\psi_{s,N}$  takes account of the disturbance of the distribution of stresses in the concrete due to edges of the concrete member. For anchorages with several edge distances (e.g. anchorage in a corner of the concrete member or in a narrow member), the smallest edge distance,  $c$ , shall be inserted in Equation (5.2c).

$$\psi_{s,N} = 0.7 + 0.3 \cdot \frac{c}{c_{cr,N}} \leq 1 \quad (5.2c)$$

d) The shell spalling factor,  $\psi_{re,N}$ , takes account of the effect of a reinforcement.

$$\psi_{re,N} = 0.5 + \frac{h_{ef}}{200} \leq 1 \quad (5.2d)$$

$h_{ef}$  [mm]

If in the area of the anchorage there is a reinforcement with a spacing  $\geq 150$  mm (any diameter) or with a diameter  $\leq 10$  mm and a spacing  $\geq 100$  mm then a shell spalling factor of  $\psi_{re,N} = 1,0$  may be applied independently of the anchorage depth.

e) The factor of  $\psi_{ec,N}$  takes account of a group effect when different tension loads are acting on the individual anchors of a group.

$$\psi_{ec,N} = \frac{1}{1 + 2e_N / s_{cr,N}} \leq 1 \quad (5.2e)$$

$e_N$  = eccentricity of the resulting tensile load acting on the tensioned anchors (see 4.2.1). Where there is an eccentricity in two directions,  $\psi_{ec,N}$  shall be determined separately for each direction and the product of both factors shall be inserted in Equation (5.2).

As a simplification factor  $\psi_{ec,N} = 1,0$  may be assumed, if the most stressed anchor is checked according to Equation (3.1) ( $N_{Sd}^h \leq N_{Rk,c}^h / \gamma_{Mc}$ ) and the resistance of this anchor is taken as

$$N_{Rk,c}^h = N_{Rk,c} / n \quad (5.2f)$$

with :

$n$  = number of tensioned anchors.

f) The factor of  $\psi_{ucr,N}$  takes account of the position of the anchorage in cracked or non-cracked concrete

$$\begin{aligned} \psi_{ucr,N} &= 1.0 \text{ for anchorages in cracked concrete (5.2g1)} \\ &= 1.4 \text{ for anchorages in non-cracked concrete (5.2g2)} \end{aligned}$$

The factor  $\psi_{ucr,N} = 1.4$  may be used only if in each individual case it is proven - as described in 4.1 - that the concrete in which the anchor is placed is non-cracked.

g) The values  $s_{cr,N}$  and  $c_{cr,N}$  are given in the relevant ETA.

*For anchor according to current experience*

$$s_{cr,N} = 2, \quad c_{cr,N} = 3 h_{ef} \text{ is taken}$$

*Special cases*

For anchorages with three or more edges with an edge distance  $c_{max} \leq c_{cr,N}$  ( $c_{max}$  = largest edge distance) (see Figure 5.3) the calculation according to Equation 5.2 leads to results which are on the safe side.

More precise results are obtained if for  $h_{ef}$  the value

$$h'_{ef} = \frac{c_{max}}{c_{cr,N}} \cdot h_{ef}$$

is inserted in Equation (5.2a) and for the determination of  $A_{c,N}^0$  and  $A_{c,N}$  according to Figures 5.1 and 5.2 as well as in Equations (5.2b), (5.2c) and (5.2e) the values

$$s'_{cr,N} = \frac{c_{max}}{c_{cr,N}} \cdot s_{cr,N}$$

$$c'_{cr,N} = c_{max}$$

are inserted for  $s_{cr,N}$  or  $c_{cr,N}$ , respectively.

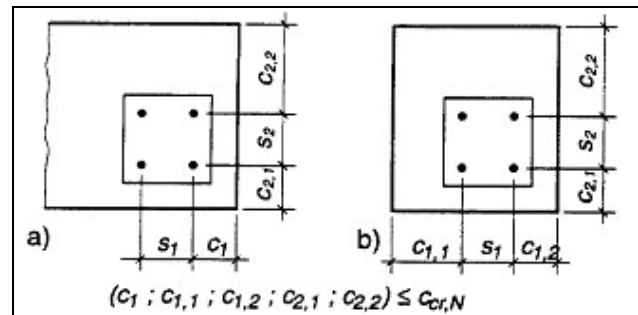

**Figure 5.3**  
Examples of anchorages in concrete members where  $h'_{ef}$ ,  $s'_{cr,N}$ , and  $c'_{cr,N}$  may be used

### 5.2.2.5 Splitting failure due to anchor installation

Splitting failure is avoided during anchor installation by complying with minimum values for edge distance  $c_{min}$ , spacing  $s_{min}$ , member thickness  $h_{min}$  and reinforcement as given in the relevant ETA.

### 5.2.2.6 Splitting failure due to loading

a) It may be assumed that splitting failure will not occur, if the edge distance in all directions is  $c \geq 1.5 c_{cr,sp}$  and the member depth is  $h \geq 2 h_{ef}$ .

b) With anchors suitable for use in cracked concrete, the calculation of the characteristic splitting resistance may be omitted if the following two conditions are fulfilled:

- a reinforcement is present which limits the crack width to  $w_k \sim 0.3$  mm, taking into account the splitting forces according to 7.3 ;
- the characteristic resistance for concrete cone failure and pull-out failure is calculated for cracked concrete.

If the conditions a) or b) are not fulfilled, then the characteristic resistance of a single anchor or an anchor group in case of splitting failure should be calculated according to Equation (5.3).

$$N_{Rk,sp} = N_{Rk,c}^0 \cdot \frac{A_{c,N}}{A_{c,N}^0} \cdot \psi_{s,N} \cdot \psi_{re,N} \cdot \psi_{ec,N} \cdot \psi_{ucr,N} \cdot \psi_{h,sp} \quad [N] \quad (5.3)$$

with  $N_{Rk,c}^0, \psi_{s,N}, \psi_{re,N}, \psi_{ec,N}, \psi_{ucr,N}$  according to Equations (5.2a) to (5.2g) and  $A_{c,N}, A_{c,N}^0$  as defined in 5.2.2.4 b), however the values  $c_{cr,N}$  and  $s_{cr,N}$  should be replaced by  $c_{cr,sp}$  and  $s_{cr,sp}$ .

$\psi_{h,sp}$  = factor to account for the influence of the actual member depth,  $h$ , on the splitting resistance for anchors according to current experience

$$= \left( \frac{h}{2h_{ef}} \right)^{2/3} \leq 1.5 \quad (5.3a)$$

If the edge distance of an anchor is smaller than the value  $c_{cr,sp}$  then a longitudinal reinforcement should be provided along the edge of the member.

### 5.2.3 Resistance to shear loads

#### 5.2.3.1 Required proofs

	single anchor	anchor group	
steel failure, shear load without lever arm	$V_{Sd} \leq V_{Rk,s} / \gamma_{Ms}$	$V_{Sd}^h \leq V_{Rk,s} / \gamma_{Ms}$	
steel failure, shear load with lever arm	$V_{Sd} \leq V_{Rk,s} / \gamma_{Ms}$	$V_{Sd}^h \leq V_{Rk,s} / \gamma_{Ms}$	
concrete pryout failure	$V_{Sd} \leq N_{Rk,cp} / \gamma_{Mc}$		$V_{Sd}^g \leq N_{Rk,cp} / \gamma_{Mc}$
concrete edge failure	$V_{Sd} \leq N_{Rk,c} / \gamma_{Mc}$		$V_{Sd}^g \leq V_{Rk,c} / \gamma_{Mc}$

#### 5.2.3.2 Steel failure

##### a) Shear load without lever arm

The characteristic resistance of an anchor in case of steel failure,  $V_{Rk,s}$  shall be taken from the relevant ETA.

*The value  $V_{Rk,s}$  for anchors according to current experience is obtained from Equation (5.4)*

$$V_{Rk,s} = 0.5 \cdot A_s \cdot f_{uk} \quad [N] \quad (5.4)$$

*Equation (5.4) is not valid for anchors with a significantly reduced section along the length of the bolt (e.g. in case of bolt type expansion anchors).*

In case of anchor groups, the characteristic shear resistance given in the relevant ETA shall be multiplied with a factor 0.8, if the anchor is made of steel with a rather low ductility (rupture elongation  $A_5 \leq 8\%$ ).

##### b) Shear load with lever arm

The characteristic resistance of an anchor,  $V_{Rk,s}$  is given by Equation (5.5).

$$V_{Rk,s} = \frac{\alpha_M \cdot M_{Rk,s}}{\ell} \quad [N] \quad (5.5)$$

where :

$\alpha_M$  = see 4.2.2.3

$\ell$  = lever arm according to Equation (4.2)

$$M_{Rk,s} = M_{Rk,s}^0 (1 - N_{Sd} / N_{Rd,s}) \quad [Nm] \quad (5.5a)$$

$$N_{Rd,s} = N_{Rk,s} / \gamma_{Ms}$$

$N_{Rk,s}, \gamma_{Ms}$  to be taken from the relevant ETA

$M_{Rk,s}^0$  = characteristic bending resistance of an individual anchor

The characteristic bending resistance  $M_{Rk,s}^0$  shall be taken from the relevant ETA.

*The value of  $M_{Rk,s}^0$  for anchors according to current experience is obtained from Equation (5.5b).*

$$M_{Rk,s}^0 = 1.2 \cdot W_{el} \cdot f_{uk} \quad [Nm] \quad (5.5b)$$

*Equation (5.5b) may be used only, if the anchor has not a significantly reduced section along the length of the bolt.*

#### 5.2.3.3 Concrete pryout failure

Anchorage with short stiff anchors can fail by a concrete pryout failure at the side opposite to load direction (see Figure 5.4). The corresponding characteristic resistance  $V_{Rk,cp}$  may be calculated from Equation (5.6).

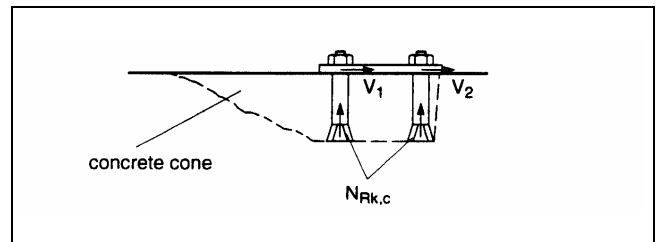

**Figure 5.4**  
Concrete pryout failure on the side opposite to load direction

$$V_{Rk,cp} = k \cdot N_{Rk,c} \quad (5.6)$$

where  $k$  = factor to be taken from the relevant ETA  
 $N_{Rk,c}$  according to 5.2.2.4 determined for the anchors loaded in shear.

For anchors according to current experience failing under tension load by concrete cone failure the following values are on the safe side:

$$k = 1 \quad h_{ef} < 60 \text{ mm} \quad (5.6a)$$

$$k = 2 \quad h_{ef} \geq 60 \text{ mm} \quad (5.6b)$$

#### 5.2.3.4 Concrete edge failure

For anchorages shown in Figure 1.1 with an edge distance in all directions  $c \geq 10 h_{ef}$ , a check of the characteristic concrete edge failure resistance may be omitted.

The characteristic resistance for an anchor or an anchor group in the case of concrete cone failure at edges corresponds to:

$$V_{Rk,c} = V_{Rk,c}^0 \cdot \frac{A_{c,v}}{A_{c,v}^0} \cdot \psi_{s,v} \cdot \psi_{h,v} \cdot \psi_{\alpha,v} \cdot \psi_{ec,v} \cdot \psi_{ucr,v} \quad [\text{N}] \quad (5.7)$$

The different factors of Equation (5.7) for anchors according to current experience are given below:

a) The initial value of the characteristic resistance of an anchor placed in cracked concrete and loaded perpendicular to the edge corresponds to:

$$V_{Rk,c}^0 = 0.45 \cdot \sqrt{d_{nom}} \cdot (l_f / d_{nom})^{0.2} \cdot \sqrt{f_{ck,cube}} \cdot c_1^{1.5} \quad [\text{N}] \quad (5.7a)$$

$d_{nom}$ ,  $l_f$ ,  $c_1$  [mm];  $f_{ck,cube}$  [N/mm<sup>2</sup>]

b) The geometrical effect of spacing as well as of further edge distances and the effect of thickness of the concrete member on the characteristic load is taken into account by the ratio  $A_{c,v} / A_{c,v}^0$  where:

$A_{c,v}^0$  = area of concrete cone of an individual anchor at the lateral concrete surface not affected by edges parallel to the assumed loading direction, member thickness or adjacent anchors, assuming the shape of the fracture area as a half pyramid with a height equal to  $c_1$  and a base-length of  $1.5 c_1$  and  $3 c_1$  (Figure 5.5).  
 $= 4.5 c_1^2 \quad (5.7b)$

$A_{c,v}$  = actual area of concrete cone of anchorage at the lateral concrete surface. It is limited by the overlapping concrete cones of adjoining anchors ( $s \leq 3 c_1$ ) as well as by edges parallel to the assumed loading direction ( $c_2 \leq 1.5 c_1$ ) and by member thickness ( $h \leq 1.5 c_1$ ). Examples for calculation of  $A_{c,v}$  are given in Figure 5.6.

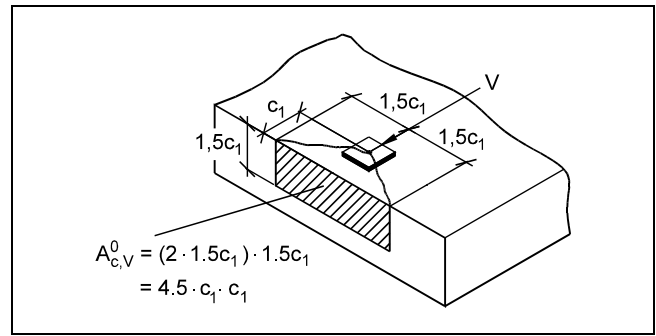

Figure 5.5 - Idealized concrete cone and area  $A_{c,v}^0$  of concrete cone for a single anchor

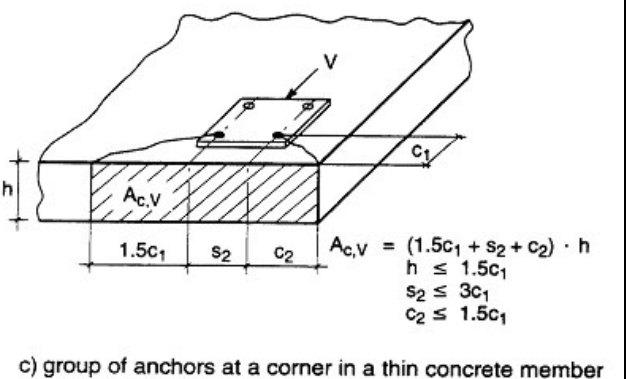
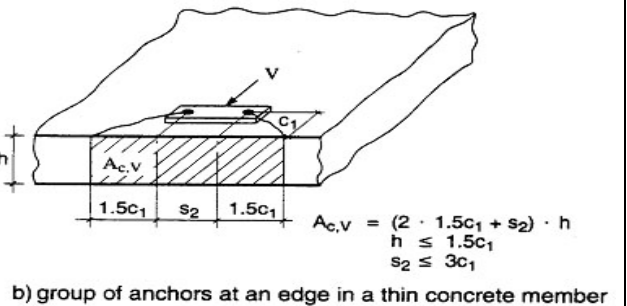
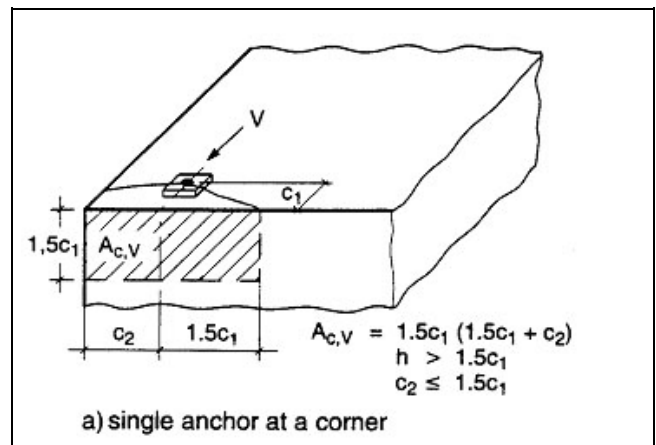

Figure 5.6 - Examples of actual areas of the idealized concrete cones for different anchor arrangements under shear loading

For the calculation of  $A_{c,V}^0$  and  $A_{c,V}$  it is assumed that the shear loads are applied perpendicular to the edge of the concrete member.

For anchorages placed at a corner, the resistances for both edges shall be calculated and the smallest value is decisive (see Figure 5.7).

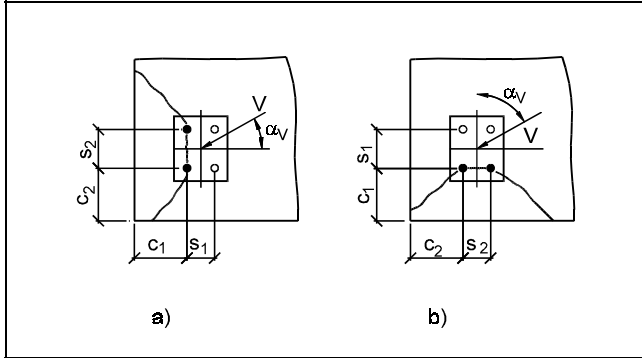

Figure 5.7 - Example of an anchor group at a corner under shear loading, where resistances shall be calculated for both edges

c) The factor  $\psi_{s,V}$  takes account of the disturbance of the distribution of stresses in the concrete due to further edges of the concrete member on the shear resistance. For anchorages with two edges parallel to the assumed direction of loading (e.g. in a narrow concrete member) the smaller edge distance shall be inserted in Equation (5.7c).

$$\psi_{s,V} = 0.7 + 0.3 \cdot \frac{c_2}{15c_1} \leq 1 \quad (5.7c)$$

d) The factor  $\psi_{h,V}$  takes account of the fact that the shear resistance does not decrease proportionally to the member thickness as assumed by the ratio  $A_{c,V} / A_{c,V}^0$ .

$$\psi_{h,V} = \left( \frac{15c_1}{h} \right)^{1/3} \geq 1 \quad (5.7d)$$

e) The factor  $\psi_{\alpha,V}$  takes account of the angle  $\alpha_V$  between the load applied,  $V_{Sd}$ , and the direction perpendicular to the free edge of the concrete member (see Figure 5.8).

$$\psi_{\alpha,V} = 1.0 \quad \text{for } 0^\circ \leq \alpha_V \leq 55^\circ \text{ area 1}$$

$$\psi_{\alpha,V} = \frac{1}{\cos \alpha_V + 0.5 \cdot \sin \alpha_V} \text{ for } 55^\circ < \alpha_V \leq 90^\circ \text{ area 2} \quad (5.7e)$$

$$\psi_{\alpha,V} = 2.0 \quad \text{for } 90^\circ < \alpha_V \leq 180^\circ \text{ area 3}$$

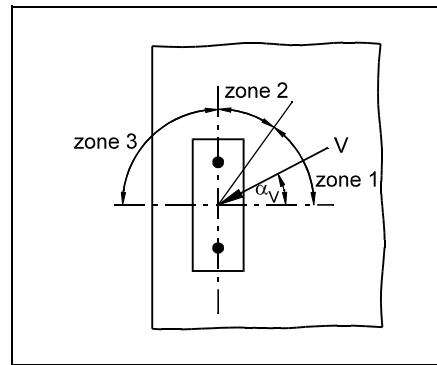

Figure 5.8 Definition of angle  $\alpha_V$

f) The factor  $\psi_{ec,V}$  takes account of a group effect when different shear loads are acting on the individual anchors of a group.

$$\psi_{ec,V} = \frac{1}{1 + 2e_V / (3c_1)} \leq 1 \quad (5.7f)$$

$e_V$  = eccentricity of the resulting shear load acting on the anchors (see 4.2.2).

As a simplification a factor  $\psi_{ec,V} = 1,0$  may be assumed, if the most stressed anchor is checked according to Equation (3.1) ( $V_{Sd}^h \leq V_{Rk,c}^h / \gamma_{Mc}$ ) and the resistance of this anchor is taken as

$$V_{Rk,c}^h = N_{Rk,c} / n \quad (5.7g)$$

with :

$n$  = number of sheared anchors

g) The factor  $\psi_{ucr,V}$  takes account of the effect of the position of the anchorage in cracked or non-cracked concrete or of the type of reinforcement used.

$\psi_{ucr,V} = 1.0$  anchorage in cracked concrete without edge reinforcement or stirrups

$\psi_{ucr,V} = 1.2$  anchorage in cracked concrete with straight edge reinforcement ( $\geq \varnothing 12$  mm)

$\psi_{ucr,V} = 1.4$  anchorage in cracked concrete with edge reinforcement and closely spaced stirrups ( $a \leq 100$  mm), anchorage in non-cracked concrete (proof according to 4.1)

#### Special cases

For anchorages in a narrow, thin member with  $c_{2,max} \leq 1.5 c_1$  ( $c_{2,max}$  = greatest of the two edge distances parallel to the direction of loading) and  $h \leq 1.5 c_1$  see Figure 5.9 the calculation according to Equation (5.7) leads to results which are on the safe side.



More precise results are achieved if in Equations (5.7a) to (5.7f) as well as in the determination of the areas  $A_{c,V}^0$  and  $A_{c,V}$  according to Figures 5.5 and 5.6 the edge distance  $c_1$  is replaced by the value of  $c'_1$ ,  $c'_1$  being the greatest of the two values  $c_{max}/1.5$  and  $h/1.5$ , respectively.

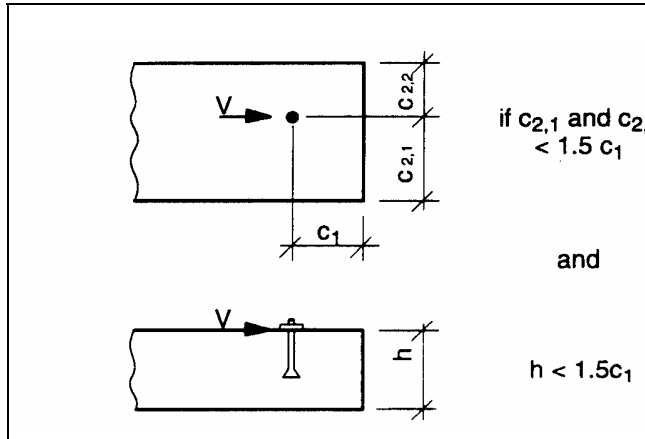

Figure 5.9

Example of an anchorage in a thin, narrow member where the value  $c'_1$  may be used

#### 5.2.4 Resistance to combined tension and shear loads

For combined tension and shear loads the following Equations (see Figure 5.10) shall be satisfied:

$$\beta_N \leq 1 \quad (5.8a)$$

$$\beta_V \leq 1 \quad (5.8b)$$

$$\beta_N + \beta_V \leq 1.2 \quad (5.8c)$$

where :

$\beta_N$  ( $\beta_V$ ) ratio between design action and design resistance for tension (shear) loading.

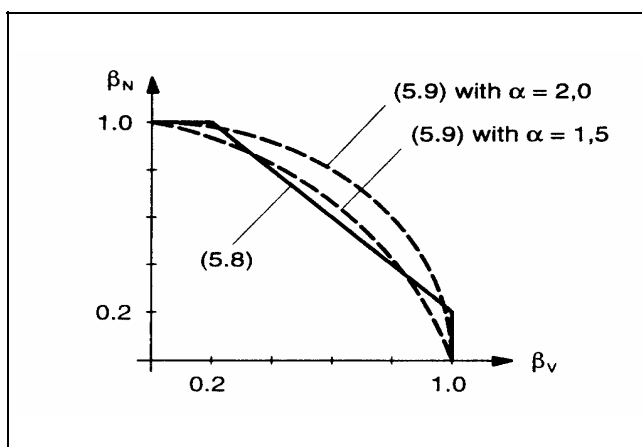

Figure 5.10

Interaction diagram for combined tension and shear loads

In Equation (5.8) the largest value of  $\beta_N$  and  $\beta_V$  for the different failure modes shall be taken (see 5.2.2.1 and 5.2.3.1).

In general, Equations (5.8a) to (5.8c) yield conservative results. More accurate results are obtained by Equation (5.9)

$$(\beta_N)^\alpha + (\beta_V)^\alpha \leq 1 \quad (5.9)$$

with :

$\beta_N, \beta_V$  see Equations (5.8)

$\alpha = 2.0$  if  $N_{Rd}$  and  $V_{Rd}$  are governed by steel failure

$\alpha = 1.5$  for all other failure modes

### 5.3 Design method B

Design method B, is based on a simplified approach in which the design value of the characteristic resistance is considered to be independent of the loading direction and the mode of failure.

In case of anchor groups it shall be shown that Equation (3.1) is observed for the most stressed anchor.

The design resistance  $F_{Rd}^0$  may be used without modification if the spacing  $s_{cr}$  and the edge distance  $c_{cr}$  are observed  $F_{Rd}^0$ ,  $s_{cr}$  and  $c_{cr}$  are given in the ETA.

The design resistance shall be calculated according to Equation (5.10) if the actual values for spacing and edge distance are smaller than the values  $s_{cr}$  and  $c_{cr}$  and larger than or equal to  $s_{min}$  and  $c_{min}$  given in the ETA.

$$F_{Rd} = \frac{1}{n} \cdot \frac{A_c}{A_c^0} \cdot \psi_s \cdot \psi_{re} \cdot \psi_{ucr} \cdot F_{Rd}^0 \quad [N] \quad (5.10)$$

$n$  = number of loaded anchors

The effect of spacing and edge distance is taken into account by the factors  $A_c / A_c^0$  and  $\psi_s$ . The factor  $A_c / A_c^0$  shall be calculated according to 5.2.2.4b and the factor  $\psi_s$  shall be calculated according to 5.2.2.4c replacing  $s_{cr,N}$  and  $c_{cr,N}$  by  $s_{cr}$  and  $c_{cr}$ . The effect of a narrowly spaced reinforcement and of non-cracked concrete is taken into account by the factors  $\psi_{re}$  and  $\psi_{ucr}$ . The factor  $\psi_{re}$  is calculated according to 5.2.2.4 d) and factor  $\psi_{ucr}$  according to 5.2.2.4 f).

In case of shear load with lever arm the characteristic anchor resistance shall be calculated according to Equation (5.5), replacing  $N_{Rd,s}$  by  $F_{Rd}^0$  in Equation (5.5a).

The smallest of the values  $F_{Rd}$  according to Equation (5.10) or  $V_{Rk,s}/\gamma_{Ms}$  according to Equation (5.5) governs.

## 5.4 Design method C

Design method C is based on a simplified approach in which only one value for the design resistance  $F_{Rd}$  is given, independent of loading direction and mode of failure. The actual spacing and edge distance shall be equal or larger than the values of  $s_{cr}$  and  $c_{cr}$ .  $F_{Rd}$ ,  $s_{cr}$  and  $c_{cr}$  are given in the relevant ETA.

In case of shear load with lever arm the characteristic anchor resistance shall be calculated according to Equation (5.5) replacing  $N_{Rd,s}$  by  $F_{Rd}$  in Equation (5.5a).

The smallest value of  $F_{Rd}$  or  $V_{Rk,s}/\gamma_{Ms}$  according to Equation (5.5) governs.

## 6 Serviceability limit state

### 6.1 Displacements

The characteristic displacement of the anchor under defined tension and shear loads shall be taken from the ETA. It may be assumed that the displacements are a linear function of the applied load. In case of a combined tension and shear load, the displacements for the tension and shear component of the resultant load should be geometrically added.

In case of shear loads the influence of the hole clearance in the fixture on the expected displacement of the whole anchorage shall be taken into account.

### 6.2 Shear load with changing sign

If the shear loads acting on the anchor change their sign several times, appropriate measures shall be taken to avoid a fatigue failure of the anchor steel (e.g. the shear load should be transferred by friction between the fixture and the concrete (e.g. due to a sufficiently high permanent prestressing force)).

Shear loads with changing sign can occur due to temperature variations in the fastened member (e.g. facade elements). Therefore, either these members are anchored such that no significant shear loads due to the restraint of deformations imposed to the fastened element will occur in the anchor or in shear loading with lever arm (stand-off installation) the bending stresses in the most stressed anchor  $\Delta\sigma = \max\sigma - \min\sigma$  in the serviceability limit state caused by temperature variations should be limited to 100 N/mm<sup>2</sup>.

## 7 Additional proofs for ensuring the characteristic resistance of concrete member

### 7.1 General

The proof of the local transmission of the anchor loads into the concrete member is delivered by using the design methods described in this document.

The transmission of the anchor loads to the supports of the concrete member shall be shown for the ultimate limit state and the serviceability limit state; for this purpose, the normal verifications shall be carried out under due consideration of the actions introduced by the anchors. For these verifications the additional provisions given in 7.2 and 7.3 should be taken into account.

If the edge distance of an anchor is smaller than the characteristic edge distance  $c_{cr,N}$  (design method A) or  $c_{cr}$  (design methods B and C), respectively, then a longitudinal reinforcement of at least  $\varnothing 6$  shall be provided at the edge of the member in the area of the anchorage depth.

In case of slabs and beams made out of prefabricated units and added cast-in-place concrete, anchor loads may be transmitted into the prefabricated concrete only if the precast concrete is connected with the cast-in-place concrete by a shear reinforcement. If this shear reinforcement between precast and cast-in-place concrete is not present, the anchors should be embedded with  $h_{ef}$  in the added concrete. Otherwise only the loads of suspended ceilings or similar constructions with a load up to 1.0 kN/m<sup>2</sup> may be anchored in the precast concrete.

### 7.2 Shear resistance of concrete member

In general, the shear forces  $V_{Sd,a}$  caused by anchor loads should not exceed the value

$$V_{Sd,a} = 0,4 V_{Rd1} \quad (7.1)$$

with:  $V_{Rd1}$  = shear resistance according Eurocode No. 2 [1]

When calculating  $V_{Sd,a}$ , the anchor loads shall be assumed as point loads with a width of load application  $t_1 = s_{t1} + 2 h_{ef}$  and  $t_2 = s_{t2} + 2 h_{ef}$ , with  $s_{t1}$  ( $s_{t2}$ ) spacing between the outer anchors of a group in direction 1 (2). The active width over which the shear force is transmitted should be calculated according to the theory of elasticity.

Equation (7.1) may be neglected, if one of the following conditions is met

a) The shear force  $V_{Sd}$  at the support caused by the design actions including the anchor loads is

$$V_{Sd} \leq 0.8 V_{Rd1} \quad (7.2)$$

b) Under the characteristic actions, the resultant tension force,  $N_{Sk}$ , of the tensioned fasteners is  $N_{Sk} \leq 30$  kN and the spacing,  $a$ , between the outermost anchors of adjacent groups or between the outer anchors of a group and individual anchors satisfies Equation (7.3)

$$a \geq 200 \cdot \sqrt{N_{Sk}} \quad a \text{ [mm] ; } N_{Sk} \text{ [kN]} \quad (7.3)$$

c) The anchor loads are taken up by a hanger reinforcement, which encloses the tension reinforcement and is anchored at the opposite side of the concrete member. Its distance from an individual anchor or the outermost anchors of a group should be smaller than  $h_{ef}$ .

If under the characteristic actions, the resultant tension force,  $N_{Sk}$ , of the tensioned fasteners is  $N_{Sk} \geq 60$  kN, then either the embedment depth of the anchors should be  $h_{ef} \geq 0.8 h$  or a hanger reinforcement according to paragraph c) above should be provided..

The necessary checks for ensuring the required shear resistance of the concrete member are summarized in Table 7.1.

### 7.3 Resistance to splitting forces

In general, the splitting forces caused by anchors should be taken into account in the design of the concrete member. This may be neglected if one of the following conditions is met:

a) The load transfer area is in the compression zone of the concrete member.

b) The tension component  $N_{Sk}$  of the characteristic loads acting on the anchorage (single anchor or group of anchors) is smaller than 10 kN.

c) The tension component  $N_{Sk}$  is not greater than 30 kN. In addition, for fastenings in slabs and walls a concentrated reinforcement in both directions is present in the region of the anchorage. The area of the transverse reinforcement should be at least 60 % of the longitudinal reinforcement required for the actions due to anchor loads.

If the characteristic tension load acting on the anchorage is  $N_{Sk} \geq 30$  kN and the anchors are located in the tension zone of the concrete member the splitting forces shall be taken up by reinforcement. As a first indication for anchors according to current experience the ratio between splitting force  $F_{Sp,k}$  and the characteristic tension load  $N_{Sk}$  or  $N_{Rd}$  (displacement controlled anchors) respectively may be taken as

$$\begin{aligned} F_{Sp,k} &= 1.5 N_{Sk} && \text{torque-controlled expansion anchors (Part 2)} \\ &= 1.0 N_{Sk} && \text{undercut anchors (Part 3)} \\ &= 2.0 N_{Rd} && \text{deformation-controlled expansion anchors (Part 4)} \\ &= 0.5 N_{Sk} && \text{bonded anchors (Part 5)} \end{aligned}$$

**Tableau 7.1**

**Necessary checks for ensuring the required shear resistance of concrete member**

Calculated value of shear force of the concrete member under due consideration of the anchor loads	Spacing between single anchors and groups of anchors	$N_{Sk}$ [kN]	Proof of calculated shear force resulting from anchor loads
$V_{Sd} \leq 0.8 \cdot V_{Rd1}$	$a \geq S_{cr,N}^{(1)} (S_{cr})^{(2)}$	$\leq 60$	not required
$V_{Sd} > 0.8 \cdot V_{Rd1}$	$a \geq S_{cr,N}^{(1)} (S_{cr})^{(2)}$ and $a \geq 200 \cdot \sqrt{N_{Sk}}$	$\leq 30$	not required
		$\leq 60$	required: $V_{Sd, a} \leq 0,4 V_{Rd1}$ or hanger reinforcement or $h_{ef} \geq 0.8 h$
	$> 60$	not required, but hanger reinforcement or $h_{ef} \geq 0.8 h$	

1. Design method A.  
2. Design method B and C.